

# CHOP CUTTER **VORTEX**

## Air Chuck Type WFC-V361A



Faster and more beautiful slice.

The most artistic frozen-meat slicer in the world has been finally launched.



**CAPACITY**  
**430** slices/min.  
**MAX**

## Improved slice precision

Incorporating Watanabe original technology, slicing precision is taken to the next level. Stable production of extra thin slices is now possible.



## Improved yield

Reduces meat loss falling into the scrap tray during slicing. The improved chucking arm minimizes the remaining end piece to as little as 20mm. It can be adjusted tool-free to 20, 30, or 40mm depending on the product, ensuring secure and reliable chucking.



## Air chuck

Air powered chucking of raw materials contributes to further labor savings.



## Improved safety

Interlock system comes standard. Blade removal tools and additional blade sensors further enhance operational safety.



## Increased productivity

Slicing speed reaches up to 430 slices/min. Thanks to Watanabe original technology, slicing precision and yield are improved even at high speeds. The touchscreen interface has also been refined for greater ease of use.



## Option

### Scattering stopper :

Suppresses scattering at the start of slicing and prevents product curling, enabling clean, uniform slices from the start to finish.



Even small pieces remain securely held without diagonal shifting.

### ■DRAWING

Please refer to the drawing for further information.

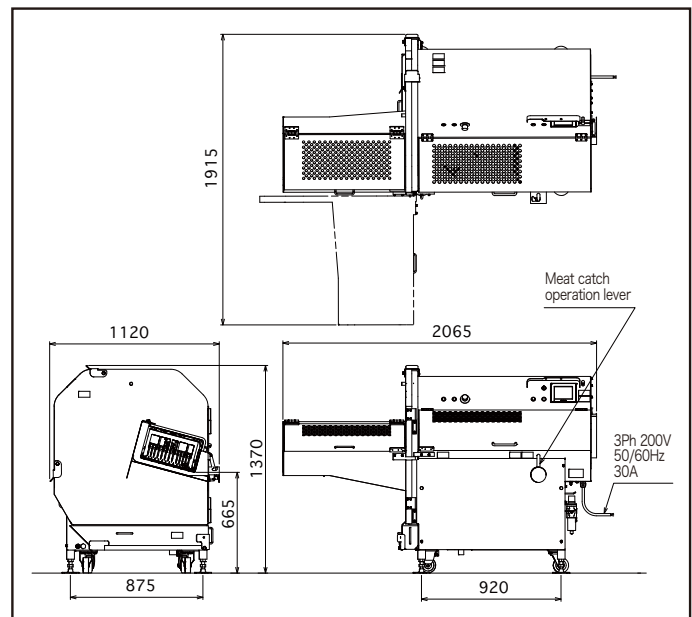

### ■仕様

DIMENSIONS	W2,065xL1,120xH1,370mm
WEIGHT	570kg
PROCESSABLE DIMENSIONS	W360xL630xH200mm
SLICE THICKNESS	0.5~30mm(0.1mm increments)
CAPACITY	100~430slices/min
SLICE TEMPERATURE	-6~-2°C(Depends on material)
SLICE ANGLE	Fixed at 0°
RATED ELECTRICAL CAPACITY	Output: 5.26kW Current: 28.1A
POWER CONSUMPTION	1.1kW/1.1kW (50/60Hz w/o load)
POWER SUPPLY	3Ph 200V 50/60Hz more than 30A
AIR CONSUMPTION	0.5MPa · 3ℓ / min
AIR CONNECTION PORT	JS-02 (JoPlax)

**WATANABE**  
WATANABE FOODMACH CO.,LTD.

2-12-26 TSUYUHASHI NAKAGAWA-KU NAGOYA JAPAN  
TEL052-361-8511 FAX052-361-8490  
URL: <https://www.foodmach.co.jp/>

SALES AGENT